

Issue 4/2016

Nebraska Rural Water Association

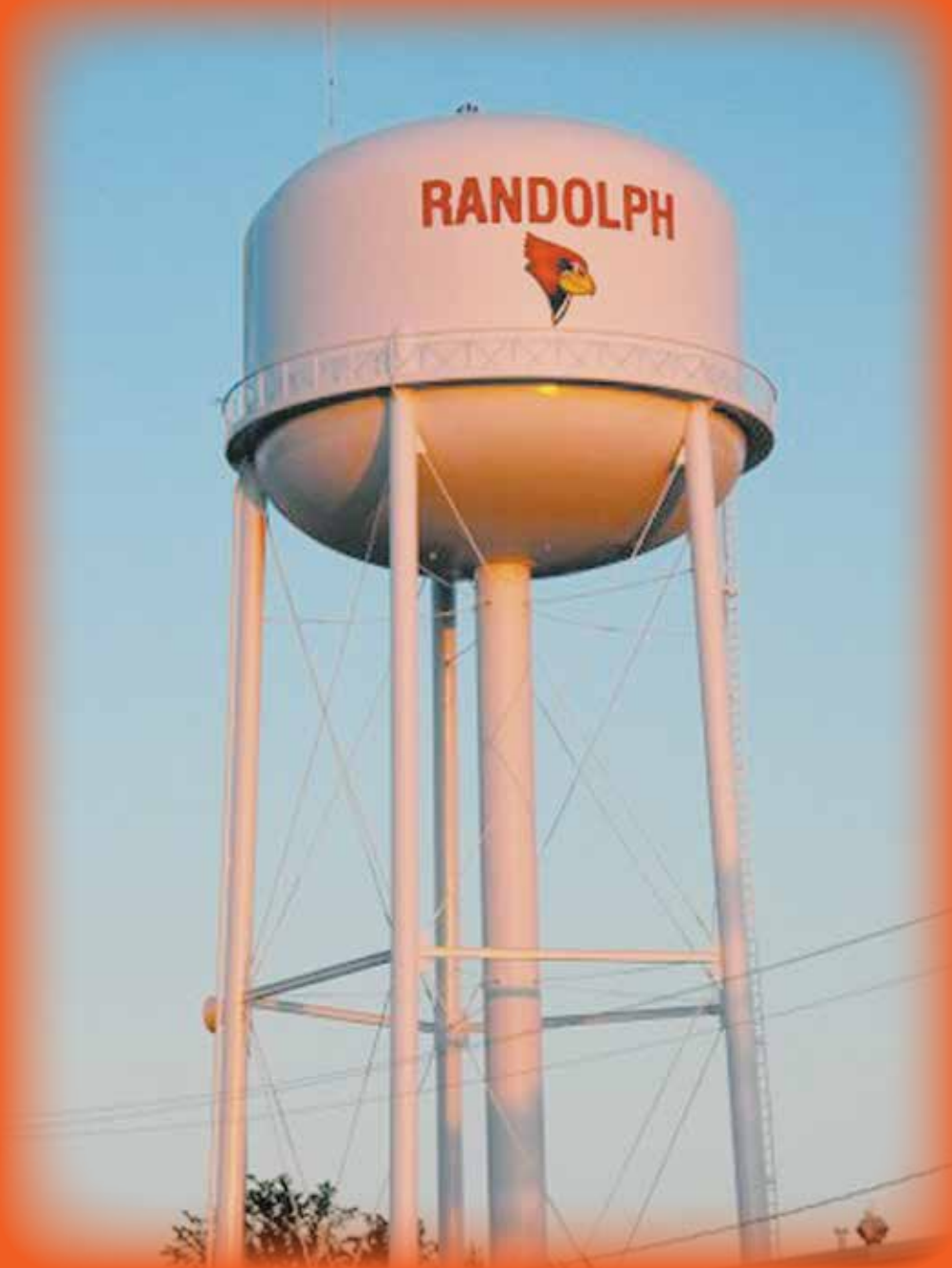

NEBRASKA GOOD WATER NEWS



1991-2016

25 Years Serving Water & Wastewater PROFESSIONALS

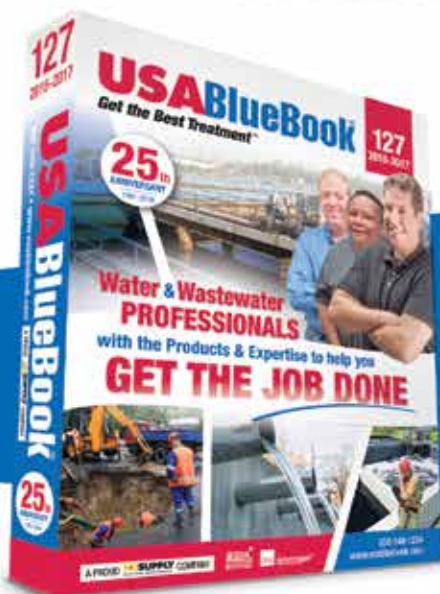

Your #1 Source for Operations & Maintenance Supplies

Since 1991, USABlueBook has provided operators with the highest quality supplies, service and support. With 64,000+ products available, USABlueBook delivers 95% of in-stock orders in 1-2 days — all backed by friendly customer service, expert technical support and a 100% Satisfaction Guarantee.

Request your **FREE** catalog today!

800-548-1234 www.usabluebook.com

USABlueBook®

A PROUD **HD SUPPLY** COMPANY
FACILITIES MAINTENANCE

Nebraska Good Water News

Issue 4/2016

“Keeping Our Water Safe”

Board of Directors

Table of Contents

Thank You Letters..... 2-3

NeRWA Annual Conference Information 4

Training for 2017..... 5

2017 Training Calendar..... 6

Annual Conference Pre-Registration..... 7

Learning and Fun 8-9

OOPS! – My Bad 10

Fall Conference Highlights..... 12-14

Water Tasting Contest 15

Hydrant Flushing and Flow Information 16

Ball Cemetery, Springfield..... 17

Summary of Evaluations 18-19

Forms and Information Links on NeRWA Website... 20

Are Your Hydrants Being Properly Maintained..... 21

USDA News Release 22

Scholarship Application..... 23-24

NeRWA Contact Information..... 25

President:

Tom Goulette, National Director
 444 S. Main St.
 West Point, Nebraska 68788
 (402) 372-2466

Vice-President:

Greg Bouc
 Box 353
 Valparaiso, Nebraska 68065
 (402) 784-2313

Secretary/Treasurer:

Larry Wennekamp
 124 E. 11th Street
 Schuyler, Nebraska 68661
 (402) 352-5444

Dennis Hoback
 317 Hoback Road
 Union, NE 68455
 (402) 235-3077

Ken Halvorsen
 Box 98
 Bennet, Nebraska 68317
 (402) 430-9078

George Wagner
 PO Box 226
 Hooper, NE 68031
 (402) 654-3649

Tom Grovijohn
 226 N. Elm
 Dodge, NE 68633
 (402) 693-2239

Staff:

Amy Kemerling, Office Assistant
 Salli Kemerling, Office Manager
 Carol Jasa, Secretary
 Randy Hellbusch, Circuit Rider
 Mike Stanzel, Circuit Rider
 Barney Whatley, GPS Specialist
 Mike Lucas, Wastewater Technician
 Pat Petersen, Training Specialist
 Doug Buresh, Source Water Specialist

Website: www.nerwa.org

On the cover:

City of Randolph's Water Tower.

"This Institution is an Equal Opportunity Provider and Employer."

“Nebraska Good Water News” is a quarterly publication of the NEBRASKA RURAL WATER ASSOCIATION, 3390 Ponderosa, Wahoo, Nebraska 68066. Phone 1-800-842-8039 or (402) 443-5216 or FAX (402) 443-5274. Copies are mailed to all member rural and municipal water operators, Federal and State Legislators, associates and individual members.

The NEBRASKA RURAL WATER ASSOCIATION is dedicated to the improvement and assistance of all public water systems in the State of Nebraska.

NOTICE: Nebraska Rural Water Association does not endorse any particular product or company in this publication. Membership and advertising should not be taken as an endorsement.

How'd We Do and Letters From...

CITY OF FAIRFIELD

October 17, 2016

Nebraska Rural Water Association
3390 Ponderosa Street
Wahoo, NE 68066

Dear Nebraska Rural Water Association,

The Mayor and Council of the City of Fairfield would like to take this opportunity to express our appreciation for all the technical assistance you have provided for our community. We are also enclosing a donation check for \$100.00 to help you continue to keep helping small communities such as ours with the specialized services you provide.

Thank you very much for all of your help.

Sincerely,

Dary A Sorensen

Mayor

Allison Peshek, Clerk/Treasurer

VILLAGE OF DUNCAN

906 Eighth Street || PO Box 254 || Duncan NE 68634-0254
Village Hall || Phone 402-897-5285 || Fax 402-897-2024

Visit us at www.villageofduncan.com or Email villageofduncan@frontier.com
Dustin Schaefer, Board Chair 402-910-5414 || Stephanie Laska, Treasurer 402-897-5285
Mari Evans, Clerk 402-897-5285 (Office Hours: M-Th 9:00am-1:00pm)

August 15th, 2016

Nebraska Rural Water Association
3390 Ponderosa DR.
Wahoo, NE. 68066

Dear NRWA,

The Village of Duncan would like to take this opportunity to thank you for all the help that you have provided to us. Everyone at NRWA has been very helpful in offering their expertise and equipment to allow us to find leaks, problem areas, blockages and root buildup. Not only has the Village benefited from the NRWA, the townspeople have as well.

We hope that you will accept the enclosed donation for whatever purpose it is best used for within your organization. We sincerely appreciate everyone at NRWA and everything that you do! The NRWA is truly a blessing to all. We hope to see you again soon!

Thank you,

Marianna Evans

Marianna Evans
Village Clerk

302 NORTH D STREET
PO BOX 307

FAIRFIELD, NEBRASKA 68938
TELEPHONE (402)726-2478
FAX (402)726-2485



Randy-

The Juniata Village Board of Trustees and myself wanted to thank you for your assistance regarding our sewer rates.

Thanks for your help!

Crystal Petzoldt
Village Clerk

VILLAGE OF SHICKLEY

Post Office Box 25, 102 N. Market
Telephone (402) 627-7885
Fax (402) 627-2085
villageofshickley@yahoo.com
SHICKLEY, NEBRASKA 68436

September 8th, 2016

Nebraska Rural Water Assoc.
Attn: Sally
3390 Ponderosa
Wahoo, NE 68066

RE: Exercising water valves and viewing sewer lines

Dear Sally:

Please find enclosed a donation in the amount of \$572.50 for the Nebraska Rural Water Association from the Village of Shickley. With help from NRWA we were able to exercise 63 water valves and use a camera to view the sewer lines in seven different areas. We sincerely appreciate the time, the use of NRWA's machine and help with this endeavor.

We always appreciate all the exemplary help, expertise and knowledge we receive from the Nebraska Rural Water Association and are happy to be able to give our support in return.

Our grateful thanks,

Village of Shickley
Board of Trustees and Staff



Village of Shelton

219 "C" Street, Post Office Box 6, Shelton, Nebraska 68876
Telephone (308) 647-5484 • Fax (308) 647-5402

August 30, 2016

Nebraska Rural Water Association
3390 Ponderosa Street
Wahoo, Nebraska 68066

To: Officials at The Nebraska Rural Water Association,

As Administrative Clerk for the Village of Shelton, I would like to extend our sincerest appreciation for the services provided to our municipality by the employees of the Nebraska Rural Water Association.

On August 10th and August 11th of 2016, Doug Buresh was on sight with our Village Utility Superintendent and Staff to exercise water valves. With Doug's assistance, knowledge and special machinery provided by your organization, 80 valves were located and exercised.

As a result, and on behalf of the Village of Shelton, I have enclosed a donation for the Nebraska Rural Water Association, as an expression of gratitude for the assistance Doug gave us on those dates above.

We are aware that a good valve exercising program extends the life of the valves and ensures system reliability so the Village can safely and effectively operate our water system. Without a doubt, the services the NRWA provide save us time and money, help solve existing problems and aid in our on-going efforts to fulfill our water system maintenance program.

We truly look forward to working with the NRWA in the future.

Sincerely,

Janice Emal
Administrative Clerk
Village of Shelton

VILLAGE OF CARROLL

JAMIE L. MUHS, CLERK
P.O. BOX 66
CARROLL, NE 68723
(402) 585-4768
villageofcarroll@yahoo.com

AUGUST 10, 2016

To Whom It May Concern,

The Board of Trustees for the Village of Carroll would like to make a donation to the Nebraska Rural Water Association. The Association was kind enough to allow our water operator use tools for flow testing on water mains and fire hydrants.

Please accept this donation and gratitude for the use of these tools.

Thank you,

Jamie L. Muhs
Village of Carroll clerk



Phone: (402) 367-3135
FAX: (402) 367-3126
Website: www.davidcityne.com

P.O. Box 191
557 4th Street
David City, NE 68632

August 15, 2016

Nebraska Rural Water Association
Attention: Mike Lucas
3390 Ponderosa
Wahoo, NE 68066

Dear Mike:

Thank you so much for locating the sewer line for the City. We truly appreciate your professional and accurate help.

Enclosed you will find a donation of \$100.00.

Thank You again!

Sincerely,

Joan E. Kovar, MMC
Interim City Administrator
City Clerk-Treasurer
jkovar@davidcityne.com
402-367-3135

**NeRWA Annual Conference
YOUNES CONFERENCE CENTER
Kearney, Nebraska**

March 13-15, 2017

The annual conference is just four months away.
Below are the hotels we will have room blocks in.

We are starting to line up the training sessions and will be sending out the topics in our Technical Action Update in December. The full agenda should be out in January.

If you are interested in registering early, the form is in this magazine.

Kearney Hotels:

Ask for NeRWA room blocks

**Fairfield Inn & Suites (connected to center)
308-236-4200**

**Comfort Inn (connected to center)
308-236-3400**

**Hampton Inn (next door)
308-234-3400**

**Wingate (next door)
308-237-4400**

**Holiday Inn Express (across the highway)
308-234-8100**



Training for 2017

By Mike Lucas, Wastewater Technician

The dates and locations for wastewater operator training have been set for 2017. Once again there will be one continuing education class scheduled monthly at locations across the state.

Please feel free to provide me with suggestions for speakers and topics. Every effort is made to have new information and timely topics presented by knowledgeable persons in the field. Any input would be very much appreciated. That helps make the training sessions better for everyone.

We will have three of our standard four-day operator certification trainings held at the NeRWA office/training center in Wahoo. Please get your registrations in early. We had to limit registrations to 20 due to room size for the November 15-18th training for 2016.

Due to multiple requests, there will be a change for next year. In addition to our standard four-day operator certification training, we will hold two lagoon only certification training classes. They will be two days each. One will be held in Wahoo and the other in North Platte. We will evaluate their success at the end of the year.

Next year I am required to hold two infrastructure sustainability sessions. This year (2016) I was required to hold one. NeRWA staff facilitated the session as a team. It was well attended and everyone participated very well. Currently they are scheduled for Albion and Ord for 2017. These sessions are intended for operators and

decision makers. Each system evaluates and prioritizes their individual utility needs. These could include water, wastewater, electric system, gas, streets, etc. The sessions are six hours long and qualify for six continuing education hours (CEU's) for both water and wastewater.

Once again, "PLEASE" provide comments and suggestions for next year's operator training classes. You can contact me at 402-443-6157 or lucas@nerwa.org.

See you all in 2017.

Water & Waste Water Solutions

Gurney

Relationships • Technology • Service



Chris Johnson
Lee Dunn
Matt Moul

Location:
4428 South 108th Street
Omaha, NE 68137

(402) 551-7995
(402) 553-5879 Fax

Sargent Drilling Co.

- **Test Well Drilling**
- **Water Well Design and Construction**
- **Complete Pump Machining Facility**
- **Pump Repair**
- **Loaner Motor Service**
- **Pump Test Labs**
- **Video Surveying**
- **Acidizing and Chemical Treatment**
- **Sonar Jetting**

Complete Municipal Water Well and Pump Service in Nebraska, Wyoming, Iowa, Kansas, Missouri, Colorado, & South Dakota

24 Hour Emergency Service

MUNICIPAL AND INDUSTRIAL DIVISION

<p>Broken Bow Office PO Box 627, 263 South 23rd Broken Bow, NE 68822</p> <p>Gary McCracken, Branch Manager Shad Yarrington, Salesman</p> <p>Office: (308) 872-5125 After Hours: (308) 870-0138</p>	<p>Geneva Office PO Box 367, 846 South 13th Geneva, NE 68361</p> <p>Doug Yantzie, Municipal Manager</p> <p>Office: (888) 496-3902 After Hours: (402) 759-2929</p>
---	--

2017 TRAINING

Grade 6 Backflow Prevention Cross-Connection Control Course - 5 Day

January 9-13	Wahoo
April 10-14	Wahoo
October 16-20	Wahoo

Wastewater Certification Course

February 21-24	Wahoo - Mechanical
April 5-6	North Platte - Lagoon
August 15-18	Wahoo - Mechanical
October 10-13	Wahoo - Mechanical
November 28-29	Wahoo - Lagoon

Wastewater Training

January 5	Wahoo
February 15	Bridgeport
March 23	Crete
April 25	Ord
April 27	Omaha
May 3	Chadron
June 1	Imperial
July 6	Wakefield
August 3	Hastings
August 24	Albion
September 7	Wahoo
October 5	Atkinson
November 2	Omaha
December 7	Burwell

Water Operator Training

January 18	Wahoo
April 4	Bridgeport
May 17	Wayne
June 14	Sutton
July 12	Chadron
August 8	Atkinson
August 10	Loup City
October 17	McCook
October 18	Axtell
November 15	Mullen
December 5	Auburn
December 20	Wahoo

Backflow Continuing Education Training

January 24	Gordon
January 25	Bridgeport
February 7	Nebraska City
February 9	Stanton
April 18	Cairo
April 19	Falls City
April 26	Wahoo
May 10	Valentine
September 26	Giltner
September 27	Ord
October 24	South Sioux City
October 25	O'Neill
November 7	Wahoo
December 5	Mitchell
December 6	Ogallala
December 7	Cambridge
December 13	Wahoo

Nebraska Rural Water Association
3390 Ponderosa
Wahoo, NE 68066
www.nerwa.org

Annual Conference

March 13-15
Younes Conference Center
Kearney, Nebraska

Fall Western Conference

Sept. 12-14
Gering Civic Center
Gering, Nebraska



August 23 Trenching & Shoring Wahoo

August 24 Confined Space Entry Wahoo

Effective January 1, 2017:

Registrations for **all fee-based** 1-day training classes and multiple day training courses will need to be made online, mailed or faxed to our office. We will no longer be taking phone registrations for **fee-based** training.

Nebraska Rural Water Association

Annual Conference Pre-Registration

March 13-15, 2017
Younes Conference Center
Kearney, Nebraska

Name (1 person per form) _____
 Water System/Company Name _____
 Billing Address _____
 Certificate Address _____
 City, State, Zip _____

**Pre-Registration
 Deadline is
 March 7, 2017**

License numbers MUST be on this form to receive the correct CEUs.

License #: Water: _____ **BF** _____ **WW** _____ I am the Voting Delegate _____

REGISTRATION INCLUDES TRAINING MATERIALS, MEALS AND BREAKS. No registrations after March 7. Registration fees after this date and on-site will increase by \$50. Monday is free for all utility/rural water board members. Board Members can attend Tuesday and Wednesday for the price of meal tickets. Board members who are also licensed operators and want CEUs need to register as an attendee.

**IF YOU SUBSTITUTE FOR AN ALREADY REGISTERED PERSON AFTER MARCH 7,
 THERE WILL BE AN EXTRA \$25 CHARGE.**

I am a Board Member attending Monday (no charge) _____
 (Cost of meals only for additional days Check if attending: Tues _____ Wed _____)

DAYS ATTENDING	Member	Member after February 27	Non-Member	Non-Member after February 27
FULL CONFERENCE (all meals)	_____ \$375.00	_____ 400.00	_____ \$425.00	_____ \$450.00
MONDAY (evening meal)	_____ \$100.00	_____ 125.00	_____ \$125.00	_____ \$150.00
TUESDAY (lunch & evening meal)	_____ \$175.00	_____ \$200.00	_____ \$200.00	_____ \$225.00
WEDNESDAY (breakfast & lunch)	_____ \$125.00	_____ \$150.00	_____ \$150.00	_____ \$175.00

All meals are included for each registration. Please indicate below if you will be staying for the evening meals. You will not be charged for them if you are registered—it's for a more accurate count. Guests need to purchase a ticket for every meal. The breakfast on Wednesday is complimentary for all registered for the conference.

Extra meal tickets available	Guest Tickets	Cost	Total	Your Meals
Mon evening		\$25	\$	
Tues lunch		\$15	\$	
Tues Banquet		\$30	\$	
Wed lunch		\$15	\$	

Name of guest _____

Registration \$ _____
 Tickets \$ _____ Total \$ _____

NeRWA member: Bill _____ Payment enclosed _____

Non-members—Payment must accompany registration or pay when checking in.

HOURS WILL NOT BE SUBMITTED UNTIL PAYMENT IS RECEIVED.

To Register:
 Online: www.nerwa.org
 Fax: 402-443-5274
 Mail: Nebraska Rural Water Association
 3390 Ponderosa Street
 Wahoo, NE 68066
NO PHONE REGISTRATIONS

When making room reservations, mention you are with NeRWA

DATE REGISTRATION RECEIVED: _____

CANCELLATION POLICY: Cancellations after March 10 and NO SHOWS will be charged a \$25 processing fee.

For NeRWA office use only: Payment received _____ Check # _____

Hours: Water _____ BF _____ Wastewater _____ Certificate mailed _____



Learning and Fun

By Pat Petersen, Training Specialist

Last year as we pulled up to the Gering Civic Center in mid-September the thermometer on the marquee out front read 96 degrees. This year as we rolled in it read 72 degrees. After a 6.5 hour drive and a long, hot summer the crisp fresh air of western Nebraska was, to say the least, refreshing! It was fall conference time in Gering. Some operators like this conference because of its relaxed atmosphere and its different extra-curricular activities. It is a more relaxed conference but the learning, sharing and problem-solving amongst operators and board members is similar to the annual conference. It's just on a smaller scale. The people in the western part of the state and the Gering Civic Center are such gracious hosts that if I was still an operator today, I would ask my leaders for a chance to attend.

The fall conference is set up a little bit different than the annual conference. On Tuesday, there is a stand-alone "pre-conference" that allows operators the chance to attend a 5 hour session that is focused on the same topic. This year, although some may think it is not important, safety was the main topic. The presenter for the 5-hour session was Bob Hessler with Safetyline Consultants. Bob has a special way of getting the operators' attention and then getting his point across. Bob has done similar pre-conferences for the Nebraska Rural Water Association in the past and this year he continued his tradition of a great pre-conference. Thanks, Bob!

Wednesday is the "kick-off" for the actual conference. Board member, Greg Bouc, welcomed all of those in attendance and led the Pledge of Allegiance to start the show. Traditionally, the drinking water administrator will give a regulation update. This year was no different. Howard Isaacs, Drinking Water Administrator with the Department of Health, gave his update and shared his time with Natalie Furrow with USDA/RD who gave her update. Bill Podraza gave us all some good advice on "Customer Relations" and Rich Koenig finished the first day of the conference by moderating an operator forum which allowed operators to share stories, ask questions and, overall, just learn from what the other operators may be going through or having a tough time with. The day went by fast and furiously and then it was time to relax with some good food, good drinks and a few awards.

The banquet was held Wednesday night. Mike Stanzel, NeRWA Circuit Rider, was the MC and gave the microphone up to Andy Kahle to present this year's Western Conference Outstanding Operator Award. This year's award went to Patrick Closson from the City of Gering. This is an outstanding tribute to a fantastic water operator! Congratulations, Pat! Wednesday night's banquet ended with the golf, trapshoot and poker run awards. The "fun stuff" was very well attended and, most of all, the generous support of our vendors and exhibitors made all of these things happen!

The final day of the conference is always the earliest and the busiest. Let's just say the cleaning lady at the Civic Center let me in "early" to get the day started. Breakfast is served at 6:30 and training sessions begin at 7:30. This year's breakfast was very well attended and the food was fantastic.

Training sessions started at 7:30 AM and concluded at 3:30 PM on Thursday. All sessions were very well attended and the presenters all did a wonderful job! Operators, whether they were there for water, well drillers, wastewater or backflow, had a chance to grab 5 or 6 more hours towards their licenses. Some of the presentations included a course on locating, math, utility technology, emergency response, trenching and shoring and a round table with the area NDHHS Field Reps.

So before I closed the tailgate on my pickup and started heading east I thought about all of the operators, vendors and companies that are associated with water/wastewater that make our fall western conference and our annual conference a success year in and year out. This year's golf sponsors were Barco Municipal Products, Hawkins Inc., HD Supply, Maguire Iron, Midco Diving, Miller and Associates, Sargent Drilling and MC Schaff and Associates. Trapshoot sponsors were Municipal Automation and Johnson Service. The social hour was sponsored by HD Supply. Also, this year the Poker Run had a sponsor, Municipal Supply.

Throughout the day on Wednesday and Thursday, operators were given the chance to win various door prizes that were given out by the exhibitors and vendors. Prizes ranged from hats, flashlights, pullovers, tackle boxes and many other

continued on page 9

items. The list of winners was quite long. If you were lucky enough to win a prize, congratulations, and if you didn't, we will have a bunch of prizes again next year!

The Gering Civic Center has a staff that goes above and beyond to help our organization. Whether there is an audio/video issue or the registration table needs coffee, it gets taken care of! The operators don't always get to see the great people that actually make these facilities work but I will say that Rick and Judy Keller are two of the best and they have a remarkable staff. Thanks, Rick and Judy!

Another very important group that complements our organization is the Nebraska Department of Health and Human Services, Department of Health Drinking Water Division. We work hand in hand with the NDHHS and they are always willing to offer training, advice and support when necessary. Thank you, Howard and your crew!

Finally, how can I forget my own team? Barney, Randy, both Mike's, Doug and the office staff of Salli, Carol, and Amy. You guys do it right. Thanks for making it fun and easy!

Many of you may have noticed that our Source Water Specialist, Doug Buresh, was not in attendance. Doug fell ill the week before the conference and is slowly on his way to recovery. We need to get you back, Doug. The annual conference is right around the corner and we need a full team to run it. Get well soon! I'm sure many operators wish you the same.

Now, is Christmas less than TWO MONTHS AWAY?? HO, HO, HO....



JEO CONSULTING GROUP
jeo.com 800.723.8567

- Water Storage
- Wells & Transmission Mains
- Distribution System - Water Treatment
- Water Rate Studies & Flow Analysis
- Water System Mapping
- Water Booster Stations
- Rural Water Districts

ARCHITECTURE • ENGINEERING • SURVEYING • PLANNING

Bartlett & West

For over 60 years — engineering clean and safe water for our communities and for you. **&you**

Water Engineering Services

- Preliminary, feasibility, and design reports
- Water source, treatment, and distribution design
- Long-range strategic and financial planning
- Regulatory compliance—strategies and planning
- GIS, GPS, and specialized system modeling
- Permitting, land rights, and easement management

BARTLETT & WEST

1200 SW EXECUTIVE DR ■ TOPEKA KS ■ 888.200.6464 ■ BARTWEST.COM



OOPS! – My Bad

By Barney Whatley, Backflow Trainer

It has been brought to my attention (several times), that I only scheduled one class in Wahoo this fall. I actually did this on purpose because this is an even numbered year, and licenses are not renewable this year. I now see that this was a mistake as many operators are trying to be proactive and keep ahead of the game in getting their continuing education hours each year instead of waiting until the last minute. To compound this error, I scheduled the fall class for the Tuesday prior to Thanksgiving, so an overflow class would need to be held on the day before Thanksgiving, and I don't want to teach a class that day and I am pretty sure operators do not want to attend a class on that day.

If it will help at all, I have scheduled two classes for the fall of 2017. One of these will be in November and the other will be in December. In addition to this, these classes are scheduled so that if they fill up early, an overflow class for each can be held on the day following the scheduled class. This will allow for additional opportunities for operators to squeeze in those needed CEUs prior to the end of the renewal year. I know how easy it is to get busy and forget to obtain those needed hours early.

I have learned my lesson and have made a mental note to schedule at least two classes in Wahoo during the fall of each year, whether or not it is a renewal year. I will also try very hard to schedule these classes so that overflow classes can be held on the days following them, if they are needed. Sometimes when you are working at a place where renewal hours are almost automatic and the opportunities to receive these hours are plentiful, it is easy to forget that many operators have a much more limited access to continuing education. I will try to keep all of the operators in the state in mind as I schedule classes so that everyone has ample opportunities to receive continuing education hours.

If operators would like to see classes in their system, or at least closer to home, there is a place on the evaluation forms for all of our continuing education classes where you can offer to host a class in your town. You do not have to be the operator for the town or even have any affiliation with them to request this. A plumber or an operator from a neighboring town can request a class to be held closer. You might not be able to host a class in your town due to a lack of a room to hold the class or a lack of somewhere for

attendees to go for lunch, but you might like to see a class just 10 miles down the road.

In August of each year, those of us who conduct training for the various operator licenses (water, backflow and wastewater) start working on scheduling classes for the upcoming year. We do go over the evaluations we have received to determine where those classes will be held, although we do not guarantee that we will always have a class where someone has requested one. We try to spread the classes around the state, but there are some communities that draw a large number of attendees and there are some that only draw a few. We do try to stick with larger classes when we have that option.

**PITTSBURG
TANK & TOWER
MAINTENANCE CO., INC.**

SAVE!
**We have a crew in
YOUR AREA!**

<u>Inspections</u>	<u>Repair</u>	<u>New & Used</u>	<u>Tanks</u>
Wet	In Service Cleaning	Relocation	Elevated
Dry	Paint	Erection	Underground
ROV	Insulation	Dismantles	Ground

ROV inspections can be viewed on TV console
During inspection & DVD provided. All inspections
Include bound reports, recommendations, and cost estimates.

Patrick Heltsley (270) 826-9000 x 4601 270-748-1325	Don Johnston (270) 826-9000 x 1001 (270) 748-1343
--	--

www.watertank.com

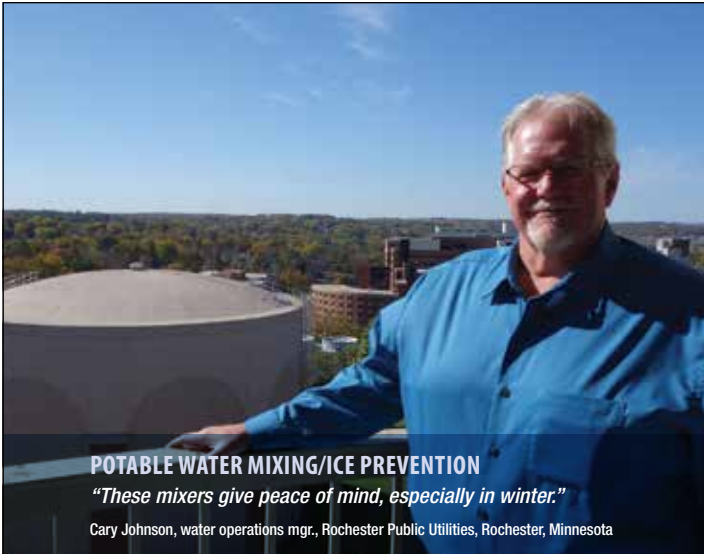

POTABLE WATER MIXING/ICE PREVENTION

"These mixers give peace of mind, especially in winter."

Cary Johnson, water operations mgr., Rochester Public Utilities, Rochester, Minnesota



POTABLE WATER/THM REMOVAL

"GridBee in-tank aeration is effective and affordable."

Tony Linder, WTP division chief, Dept. of Water Supply, County of Maui, Hawaii

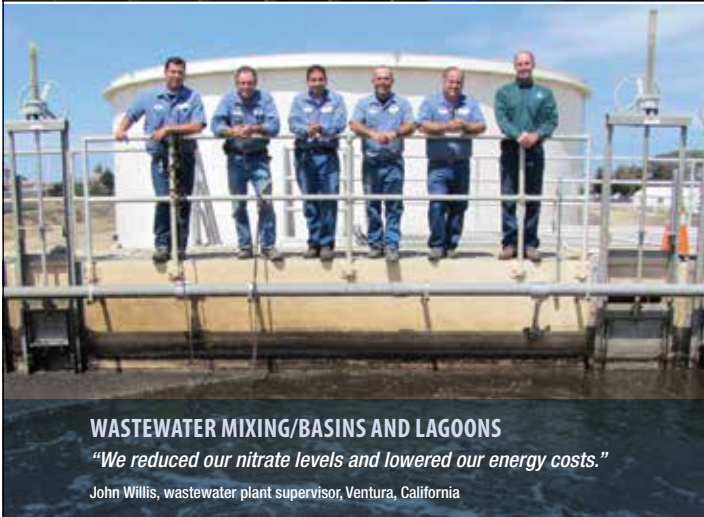

WASTEWATER MIXING/BASINS AND LAGOONS

"We reduced our nitrate levels and lowered our energy costs."

John Willis, wastewater plant supervisor, Ventura, California



LAKES AND RAW WATER

"We reduced WTP operating costs caused by algae blooms."

James A. Brown, water production manager, Newton County, Georgia



WASTEWATER MIXING/WET WELLS

"Don't let wipes clog your pumps."

Curtis Rooth, foreman, Sewer Dept., Cromwell, Connecticut

Improve all of your water

Water operators and engineers rely on GridBee® electric and air-powered mixers and SolarBee® circulators to help reduce operating costs, achieve better compliance and improve water quality. Factory field service available.

Call us today for prompt, friendly service and fast, reliable results. 1-866-437-8076

Medora Corporation | GridBee® SolarBee®
Dickinson, ND • www.medoraco.com • 866-437-8076 • info@medoraco.com

We're expanding!
District Sales Management
dm@medoraco.com
Positions Open Nationwide

FALL CONFERENCE



ANCE HIGHLIGHTS



continued on page 14

FALL CONFERENCE HIGHLIGHTS





ANNUAL WATER TASTING CONTEST MARCH 2017

As most of you already know, NeRWA has a best tasting water contest at the Annual Conference each year.

Last year the Village of Cortland won and will be sending their water to the national water tasting contest that is being held at the Water Rally in Washington DC on February 7. It is possible for any of your systems to win the National Contest. Remember to submit your water at the conference in March.

The water contest is to be held at the Conference in Kearney. A panel of distinguished taste testers will judge all samples. The winner will be announced at the banquet on Tuesday, March 14. The winning system will compete against finalists from the other 49 states in the National Contest at the National Rural Water Association Water Rally in Washington DC.

Contest Rules:

1. Sample must be from a Nebraska public water supply system
2. One entry per water system
3. Water must come before any point-of-use treatment
4. Water must come from the distribution system
5. Water should be in clean, unmarked gallon container
6. **Entry form must accompany sample**

Water must be received by 3:00 pm on Monday, March 13, at the conference registration table.

Water System: _____

Submitted by: _____

If at all possible, please call our office in advance at 800-842-8039 or 402-443-5216 or email to salli@nerwa.org to let us know you are entering. Thank you.

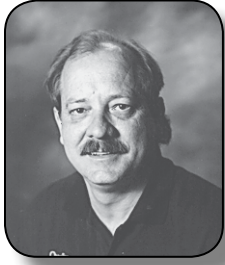

Hydrant Flushing and Flow Information

By Randy Hellbusch, Circuit Rider

The past year or so NeRWA has gotten increased calls for equipment to conduct fire hydrant flows. We currently have 2 gauged hydrant diffusers with direct read gauges. These diffusers make checking hydrant flows simple and also assist with diverting the water so as not to damage streets or lawns, etc. Feel free to contact any of us at NeRWA if yo would like to use this equipment or would like some assistance with conducting hydrant flow tests.

There are however other options to conduct hydrant flows that do not require sophisticated equipment, only a simple pressure gauge and the chart shown below.

GAUGE READING IN PSI	FLOW IN GPM	GAUGE READING IN PSI	FLOW IN GPM
1	170	15	650
2	240	16	670
3	290	17	690
4	340	18	710
5	380	19	730
6	410	20	750
7	440	25	840
8	480	30	920
9	500	35	990
10	530	40	1055
11	560	45	1120
12	580	50	1182
13	610	55	1240
14	630	60	1294

HYDRANT ON FULL

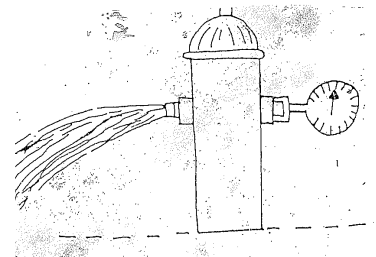

Another thing to keep in mind is that a very important aspect of any hydrant flushing program is public relations. It is always an excellent idea to keep the public informed. Below is a sample message that many systems use to inform the public when hydrant flushing is going to occur and why it is being done.

SEASONAL FIRE HYDRANT FLUSHING

The City of _____ Water Department personnel would like to inform all water customers that they will begin flushing fire hydrants in the next few weeks. The purpose for this process is to insure the proper functioning of all fire hydrants and to draw attention to those in need of repairs. This process is also helpful in the removal of iron and manganese from the city water mains. During this procedure you may experience a few unfavorable occurrences with your water supply. Such problems may be a reduction in your water pressure, a discoloration of the water supply and some plugging of your faucet aerators. It is recommended that you do not use any water when you notice hydrants are being flushed in close proximity of your home. This should help reduce the chances of loose floating iron and manganese particles from entering your water service. To remedy these problems clean your sink faucet aerators if they should become plugged and flush a portion of water from your lines to clear up any discoloration before consumption. Water pressure should return to normal following this process. If you continue to have problems feel free to contact city personnel. Water personnel would like to apologize for any inconvenience this may cause but hope you understand that it is necessary.

Ball Cemetery, Springfield

Just your typical haunted cemetery here. You know the deal: The ghost of a tall male who walks around in the middle of the night attacking and strangling visitors, unexplainable bruises appearing randomly after visits, the faint voice of a woman followed by maniacal laughter, strange ectoplasm mists appearing in photographs, and headstones tipping over and rising back up on their own. The usual stuff. Adding to the frights, the very-much-alive, shotgun-toting next-door neighbors guard the cemetery at night, so you might want to pass on visiting this one without permission.

(Story taken from Scariest Places in Every State on the internet)



2017 NeRWA Training Calendar

At the most recent coalition meeting it was brought up that there will not be a coalition calendar produced by NDHHS for 2017. In its place NeRWA will be putting together a calendar with all of NeRWA's training for 2017. It will be mailed out to all member water/wastewater operators by the end of December 2016.

2017 Membership Directory

The 2017 membership directory is being compiled. If we do not receive the information that was requested from you, the information on your most recent membership renewal form will be used. The directory will be printed and mailed out to all NeRWA members in January 2017.

2016-2017 Water and Sewer Comparison Study

If you are interested in comparing your system's water/sewer rates with other communities of a similar size, you could find that information in NeRWA's "2016-2017 Water and Sewer Rate Comparison Study." You would also be able to compare deposit, tapping, disconnect and reconnect fees. You can request a study on our website, nerwa.org

Summary of Evaluations

NeRWA Fall Conference

TOTAL EVALUATIONS RECEIVED – 45

QUESTION # 1 – Please circle which best describes your position:

a. Operator/Manager	30
b. Administrative	1
c. Board Member	1
d. Plumber	3
e. Lawn Service	1
f. State/Federal Rep.	1
g. Clerk	1
h. Other:	
Consultant – 1	
Well Monitoring Tech. - 2	

Double positions:

- Operator/Manager and Board Member – 2
- Operator/Manager and Administrative – 1
- Operator/Manager and Engineer - 1

QUESTION # 2 – Why do you attend the NeRWA conference?

a. The training classes	15
b. The vendors	0
c. Chance to meet with operators	4
d. All of the above	30

QUESTION #3 – Things you liked and why?

- Safety training. Vendors – new products available. Trap shoot – good chance to mingle & socialize. Bill Podraza – personal development education. Nice venue – convention center, Gering.
- Bob Hessler is always energetic and has no problem keeping your attention.
- The conference was great. Food was excellent.
- Customer Relations program (Bill Podraza) – one of the best I have heard.
- Variety of speakers & topics.
- The speakers and subjects were really good! Helpful information!
- Convenience in getting continuing education. Variety of topics. Runs smooth.
- Enjoyed all of the classes. They were very informative.
- The Western NE conference is always a great one, a great chance to meet one-on-one with operators, industry and regulators. Rich's talk on Wednesday was a great, interactive learning from one-another session. The pork @ the banquet was excellent!

- Convenience.
- Instructional sessions were good and refreshing for the brain.
- Very informative speakers know what they are talking about. Breakfast & lunch were good. Always enjoy them.
- The customer relations presentation on Wednesday.
- Good information.
- All the information.
- Good classes.
- All the booths. Was able to learn about the variety of equipment.
- I really like the vendors and seeing what's new on the market and different services provided.
- Came to learn about the new regs and what is coming in the future.
- USDA, good speaker.
- It is a laid-back conference. Has great food and other things to do other than attend class.
- Bob Hessler and Bill Podraza (speakers I have not heard before) were very good.
- All.
- Really liked the speaker about conflict.
- Rich's classes are always enjoyable.
- The location – 45 minute drive to home.
- Vendors.
- Exhibit area, meals, banquet and awards.
- Great facility & things run very nicely.
- Location in Gering at Civic Center – close by. Like vendors' displays – can talk to reps about needed parts directly. Trap shoot, poker run, golf tournament.
- Training & classes are good. Good information available.
- Nice clean venue building. Helpful classes. Good speakers.
- I always enjoy this conference. It's a little smaller and people can talk more and relax. Everything was great!
- The update on new regs on how they are changing.
- The location of conference. Backflow classes are a good learning tool.
- The info we were given, reminders on regs and how to better ourselves in our job.
- The presentations were all well done
- Great conference.
- Liked the wide variety of sessions to select from.

- Classes & instructors – knowledge of speakers.
- Interesting classes – informative. Good food. Venue – close as possible to home. Enjoy visiting with vendors.
- Excellent presentations. Good location.

- Food – great. Vendors – great. NeRWA – great. Field Rep Panel – great sessions.
- Having State folks from Lincoln come out is much appreciated.
- None.
- Overall a good conference.
- Bob Hessler was very good!!!
- My first conference!
- Non-smoking in the area.
- Overall the conferences are very good and have lots of great info. to help new & old operators in their jobs.
- Good to see you all!

QUESTION # 4 – Things you disliked and why?

- Sound system with Howard Isaacs. USDA - ??? funding for housing??? Not as many vendors as March meeting. Many topics on Thursday are the same year after year.
- None. (7 of this response.)
- More selections for advanced water operator.
- Can't think of anything.
- Would be great to have more hotel space near the convention center.
- So late in the fall.
- Everything was great. Nothing to dislike.
- Rooms a little cold.
- Being talked down to by instructor. We do some things right, you know.
- First time here. Not sure there is any.
- Seem to have the same speakers over & over.
- Info coming from EPA. The drive from Palmyra. (my fault) DO NOT, I REPEAT, DO NOT stay at Circle S Motel!!!
- All the smoking & the smell from them after breaks.
- The location – I still had to go home.
- More handouts on Tuesday and Wednesday.
- Nothing.
- They could use another motel closer to the Center but I heard that should happen in the near future.
- Nothing negative to comment on.
- All okay.



QUESTION # 5 – Any suggestions for future conferences?

- None. (11 of this response.)
- More hands-on exercises if possible.
- Keep up this conference – it's a great one!
- No recommendations.
- Put backflow knowledge in morning before some leave for home.
- More hands-on.
- Same format – keep.
- Would like to see some hands-on work.
- Continue the good work.
- Not really. I think they are run very well.

ADDITIONAL COMMENTS:

- Best trenching safety presentation ever! Kris!
- Food was scrumptious as usual.
- Nebraska Rural Water does a great job for the spring & fall conferences.

MUNICIPAL PIPE SERVICES

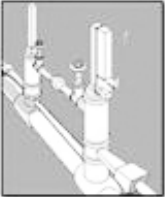
-LINE STOPPING	3/4" - 60"	
-LINE TAPPING	2" - 60"	
-VALVE INSERTION	4" - 16"	
-VALVE TURNING		
-PIPE REPAIR		

For all your **POTABLE** and **WASTE WATER** needs

BOB HENNIG
SALES MANAGER
1615 WEST "J" STREET
HASTINGS, NE 68902

1-800-395-7473
CELL: 402-469-1886
FAX: 402-462-4408
E-MAIL: BOB@MUNICIPALPIPESERVICES.COM



WWW.MUNICIPALPIPESERVICES.COM

The following forms and informative links can be found on our website Downloads Page.

Backflow Brochures

- Backflow Testing Forms
- Let's Work Together for Safe Water
- Protecting Your Family and Your Community
- Helping Keep Our Water Safe
- Common Backflow Preventers and Their Uses

Backflow Testing Forms

- PVB Test Procedures
- DC Test Procedures
- RP Test Procedures
- PVB Test Report
- DC Test Report
- RP Test Report

Backflow Surveys

- Residential CCC Survey (pdf file)
- Commercial CCC Survey (pdf file)
- Residential CCC Survey (word file)
- Commercial CCC Survey (word file)

Wastewater Smoking Forms

- Smoke Candle MSDS Sheet
- Sample Sewer Smoking Letter
- Sample News Release

- WaterSense: Efficiency Made Easy (EPA)
- Water Infrastructure Security (EPA)

Need help with Abandoned Wells?

- Emergency Contact List
- NDEQ Wastewater Continuing Education Hours

- Sample Site Plan
- Short-Term Chlorination Reporting Form

Made in the USA!

Look to Ford Meter Box for U.S. manufactured products

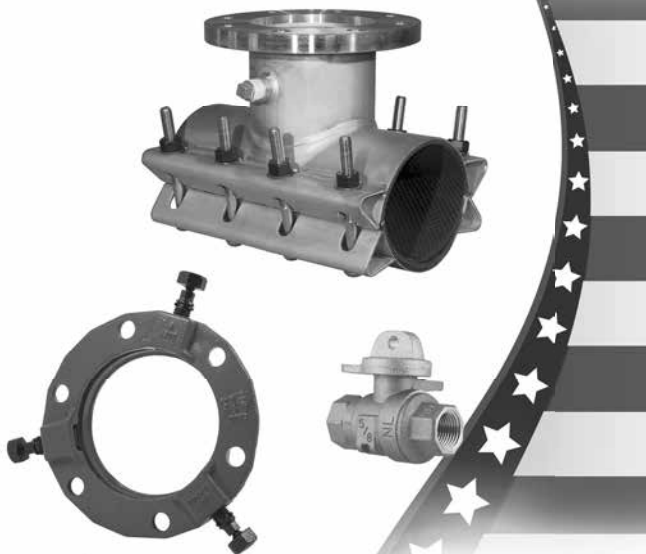

FORD www.fordmeterbox.com/usa
260-563-3171

Contact Ford Meter Box for AIS and Buy America compliant products

Municipal Automation & Control

municipalautomation.com

Design, Build, Service

WATER / WASTEWATER CONTROL SYSTEMS

211 N. Tyler
PO Box 393
Elm Creek, NE 68836
Office/Fax: (308) 856-4730

Bill Simmerman - Owner
Cell: (308) 233-4729
bill.s@municipalautomation.com



DYK and Natgun Generations Strong



Sustainable Infrastructure

Prestressed Concrete Water Storage Tanks

913.681.6006 | www.dntanks.com
Dave Ornduff, Regional Manager
dave.ornduff@dntanks.com



Are Your Hydrants Being Properly Maintained?

By Mike Stanzel, Circuit Rider

Being a water operator and doing town maintenance, you can acquire a list of responsibilities a mile long. So I completely understand when something gets overlooked, neglected or put off.

The inspiration for this article came from the fact that I assisted with repairing 5-6 hydrants in the past 6 months. Let's get this out in the open first. I am not an EXPERT on fire hydrants by any means but I do enjoy learning and refreshing my brain due to the fact that I don't repair them very often and there are so many different brands.

I believe a hydrant gets overlooked because it just sits there on the corner or the end of the line just waiting and waiting and waiting to get used. I mean, realistically, they are for fighting fires, correct? And how many house fires do we get in towns on a yearly basis? Maybe 1 or 2, but you might have 20-200 plus fire hydrants depending on the size of your town, and frankly it's a lot of work to maintain them. Not to mention the cost of replacing inoperable hydrants can be in excess of \$2000 each.

I have done a lot of leak detection in my 8 years with NeRWA and I have literally listened to thousands of hydrants. Some amaze me by their shape, style and color but mostly by the age of some of them that are still in service. I have seen some dating back to the early 1900's. So a piece of advice, when replacing the old ones, SAVE them as they are worth quite a bit of money as people pay dearly to turn them into yard ornaments.

So back to the maintenance part, a lot of hydrants sit idle as some towns don't have a flushing program. Some towns rely on the Fire Department to flush, which is fine but the operator should still be involved. It's a good practice to flow test the hydrants with the Fire Department so you know which ones flow more water and can label them accordingly. As with all valves, if hydrants are not being exercised regularly, they can become hard to operate. Most have a set screw on the top bonnet so they can be lubricated with oil. A lot of times we find that when there is no oil at all, they tend to seize up. It's actually pretty simple to fix. If one is hard to open, take it apart, clean everything, lubricate and reassemble. Most recently we repaired one that would not open and when we were finished, we could open and close it with one hand effortlessly.

Another thing is to make sure the caps, including the steamer, are easily removable. This can be done by putting anti-seize on the threads. You certainly don't want it falling back on the city if a house catches fire and the Fire Department cannot get water out of the closest hydrant. It's a lawsuit waiting to happen.

Make sure your hydrants are free from debris, weeds, trees, shrubs, etc. and easily accessible especially in the winter. I've seen a lot of towns put a note in their water bills or local paper asking residents to scoop the snow away from the hydrants in front of their property in the winter and have had excellent results.

So if you need assistance with evaluating your fire hydrants please contact me at 402-672-9084 or mike@nerwa.org.



ELECTRIC PUMP
Proudly Serving the Municipal/Industrial Water
and Wastewater Market in: Iowa, Illinois, Minnesota, Nebraska,
North Dakota, South Dakota and Western Wisconsin

Des Moines, IA
515-265-2222 / 800-383-PUMP (7867)

New Prague, MN
952-758-6600 / 800-211-6432

Fargo, ND
701-293-0204

Omaha, NE
800-383-7867

www.electricpump.com
Factory authorized shop and field
service for all products offered



Process Equipment is offered by EPI Environmental.
Please see the website at www.epi-environmental.com



United States Department of Agriculture

Office of Communications
1400 Independence Ave, SW
Washington, DC 20250-1300
(202) 720-4623
oc.news@usda.gov
www.usda.gov

News Release

Release No. 0235.16

Contact:
Anne Mayberry (202) 690-1756

USDA Announces \$331 Million Investment for Clean Water Infrastructure in Rural Communities *Nearly Half of Grant Funds to Assist Persistently Poor StrikeForce Counties*

WASHINGTON, Nov. 1, 2016 -Agriculture Secretary Tom Vilsack today announced that the U.S. Department of Agriculture (USDA) is investing \$331 million in 85 projects that will improve water and wastewater infrastructure in rural areas in 39 states and American Samoa. Community infrastructure investments are a key piece of USDA's mission to support America's rural communities, and these investments build on the \$13.9 billion USDA has invested over the course of the Obama Administration to support 5,825 water and waste infrastructure projects that currently benefit 19.5 million rural residents.

"Strategic investments like these into community infrastructure provide a path to rural economic growth," Vilsack said. "Water and wastewater upgrades protect the health and safety of those who live and work in rural areas, and are especially critical given today's aging infrastructure in areas that have not fully benefited from rural America's economic rebound. Modernizing water and wastewater systems improves the quality of life and can help attract jobs to rural communities."

USDA is providing \$264 million in loans and \$67 million in grants through Rural Development's Water & Environmental Programs. These programs provide assistance and financing to develop drinking water and waste disposal systems for communities with 10,000 or fewer residents.

For example, in South Carolina, the Laurens County Water and Sewer Commission is receiving a \$34.8 million USDA loan and a \$1.2 million USDA grant to construct a water treatment plant. Currently, the Commission purchases water from three separate water systems, whose infrastructure is aging.

The Summit Springs Regional Waste District in Henry County, Ind., is receiving a \$1.4 million loan and a \$4.2 million grant for a sewer rehabilitation project to address raw sewage leakages and to comply with environmental regulations.

The city of Truth or Consequences in Sierra County, N.M., has been selected for a \$715,000 loan and a \$4.5 million grant for the second phase of wastewater treatment plant improvements to comply with environmental regulations. Sierra County is included in USDA's StrikeForce for Rural Growth and Opportunity initiative to address persistent poverty across America.

Of the 85 projects announced today, 21 are located in StrikeForce areas, and one project- an Emergency Community Water Assistance Grant in Jackson, Ky., - is also in an area targeted for assistance by the Obama Administration's Promise Zone initiative. These 21 projects are receiving more than \$63 million in loans and \$30 million in grants, which is 28 percent of today's total investment and nearly 45 percent of the grant funding.

Funding for each project announced today is contingent upon the recipient meeting the terms of the loan, grant or loan/grant agreement.

Today's funding builds on USDA's historic investments in rural America over the past seven years. Since 2009, USDA has worked to strengthen and support rural communities and American agriculture, an industry that supports one in 11 American jobs, provides American consumers with more than 80 percent of the food we consume, ensures that Americans spend less of their paychecks at the grocery store than most people in other countries, and supports markets for homegrown renewable energy and materials.

Since 2009, USDA Rural Development (@USDARD) has invested \$13.9 billion for 5,825 water and waste infrastructure projects, benefiting 19.5 million rural residents; invested nearly \$13 billion to start or expand nearly 112,000 rural businesses; helped 1.1 million rural residents buy homes; funded nearly 9,200 community facilities such as schools, public safety and health care facilities; and helped bring high-speed Internet access to nearly 6 million rural residents and businesses. USDA also has invested \$38.2 billion in 1,057 electric projects that have financed more than 198,000 miles of transmission and distribution lines serving 4.6 million rural residents. For more information, visit www.usda.gov/results.

To read more about USDA's investments in rural America and its successful turnaround, visit USDA's entry on Medium.com, Rural America Is Back in Business.

USDA is an equal opportunity provider, employer and lender.

**NEBRASKA RURAL WATER ASSOCIATION
SCHOLARSHIP APPLICATION 2017**

Personal Data

NAME _____
Last First Middle
ADDRESS _____ CITY _____ STATE _____ ZIP _____

Eligible System Employee Data

NAME _____ TITLE _____
ADDRESS _____ CITY _____ STATE _____ ZIP _____
MEMBER SYSTEM _____ TELEPHONE _____
RELATIONSHIP TO APPLICANT _____ EMAIL _____

High School Data

SCHOOL NAME _____ GRADUATION DATE _____
ADDRESS _____ CITY _____ STATE _____ ZIP _____
YOUR CLASS RANK _____ NUMBER OF STUDENTS IN CLASS _____ YOUR GRADE POINT AVERAGE _____
(Transcript must be submitted with application)

LIST BELOW ANY ACADEMIC AWARDS, MEMBERSHIPS OR OTHER SPECIAL RECOGNITION YOU HAVE RECEIVED DATING BACK TO YOUR SOPHOMORE YEAR.

College/University Data

IS THIS YOUR FIRST YEAR OF HIGHER EDUCATION? YES _____ NO _____ IF NO, CREDIT HOURS COMPLETED _____
NUMBER OF CREDIT HOURS REQUIRED TO GRADUATE _____ COLLEGE GRADE POINT AVERAGE _____
SCHOOL NAME _____
ADDRESS _____ CITY _____ STATE _____ ZIP _____

PLEASE INDICATE: _____ 4-YEAR COLLEGE/UNIVERSITY
_____ 2-YEAR COMMUNITY/JUNIOR COLLEGE
_____ VOCATIONAL TECHNICAL SCHOOL

MAJOR COURSE OF STUDY _____

Priority will be given but not limited to water related studies.

(For those already in college, a first semester transcript or grade report and second semester enrollment must accompany application)

Essay

ON A SEPARATE PAGE IN 250 WORDS OR LESS, WRITE A BRIEF MESSAGE ON YOUR GOALS AS THEY RELATE TO YOUR EDUCATION, CAREER AND FUTURE PLANS

Certification

IN SUBMITTING THIS APPLICATION, WE CERTIFY THAT THE INFORMATION PROVIDED IS COMPLETE AND ACCURATE TO THE BEST OF OUR KNOWLEDGE. FALSE INFORMATION WILL RESULT IN THE REVOCATION OF ANY SCHOLARSHIP GRANTED.

Applicant's Signature _____ Date _____

Parent Signature _____ Date _____

continued on next page

NeRWA SCHOLARSHIP APPLICATION

The Nebraska Rural Water Association is pleased to announce it will be presenting two \$1000 scholarships for higher education purposes for the school year 2016-2017 fall and spring semesters. The scholarship is available to children and stepchildren of member public water system employees. Employees of the Nebraska Rural Water Association Board of Directors and staff are not eligible. Interested persons should complete and submit the application in this mailing. Applications are due March 1, 2017. Please type or print – printing must be legible. Winners of the Scholarships will be announced at the Columbus Conference in March. Send all information to the NeRWA address.

Official Rules

This grant of Five Hundred Dollars (\$1000) will be made to a student to defray the cost of tuition, books, or room and board at an accredited institution of higher learning approved by the Nebraska Rural Water Association (NeRWA). Disbursement of the money will be made upon presentation of winner's college or university invoice as proof of full-time enrollment. The scholarship money will be paid directly to the student, two hundred fifty dollars (\$500) per semester. The scholarship will be awarded to children or stepchildren of member utility system employees. In order to be eligible for scholarship, applicants must complete the application form in its entirety by filling in all blanks. If item is not applicable please place a N/A in the blank. Upon completion return it to the NeRWA Scholarship Committee by the entry deadline, March 1, 2017. All applications will be first screened on the basis of leadership responsibilities in community and school activities as well as grade point average. Applicants will be evaluated on a comparative basis at the sole discretion of the committee. Decisions will be final. Application material and decisions of the committee shall be confidential. Acceptance of scholarship constitutes permission to use recipient's name and/or likeness for purpose of promotion.

WE ARE AN **AMERICAN** TRADITION

WE ARE MAGUIRE IRON

We've been providing communities with functional landmarks since 1915. Maguire Iron designs, fabricates, erects, paints and repairs water towers and tanks. We look forward to the next century with great pride as a family-owned American company.



MAGUIREIRON.COM | 605 334-9749

WATER TOWER SPECIALISTS



Nebraska Good Water News

Nebraska Rural Water Association - 3390 Ponderosa Drive - Wahoo, NE 68066
 Home | Office | Membership Info | Training | Annual Conference | Fall Conference | EXPO

Contact NeRWA... ▼

NeRWA Staff

Water Circuit Rider I
Water Circuit Rider II
Training Specialist
Wastewater Tech.
Sourcewater Protection Specialist
Capacity Development Specialist
Office Manager
Secretary
Board of Directors
Office Assistant



News & Downloads Page NEW

Register on Line for Training
 Available Equipment



BARTLET
 SERVICE. THE BARTL



Informational Links

National Rural Water
USDA Rural Development
NE Public Water Supply
HHS License Information
SDWIS System Data
EPA Wastewater
EPA Drinking Water
Nebraska DEQ
League of Municipalities
Nebraska Section, AWWA
AWWA Library Reference Listings
NeRWA Associate Members

NeRWA Contact Information:

Nebraska Rural Water Association
 3390 Ponderosa Street
 Wahoo, NE 68066

Office phone numbers:

800-842-8039
 402-443-5216
 Fax: 402-443-5274
 Website: www.nerwa.org
 Email: office@nerwa.org



Cell

Email

Randy Hellbusch	402-443-8535
Mike Lucas	402-443-6157
Pat Petersen	402-277-6699
Mike Stanzel	402-672-9084
Doug Buresh	402-480-4196
Barney Whatley	402-480-4297
Salli Kemerling	402-443-7072
Carol Jasa	
Amy Kemerling	

randy@nerwa.org
lucas@nerwa.org
pat@nerwa.org
mike@nerwa.org
doug@nerwa.org
barney@nerwa.org
Salli@nerwa.org
Carol@nerwa.org
Amy@nerwa.org

Nebraska Rural Water Association

3390 Ponderosa
Wahoo, NE 68066

PRSR STD
U.S. POSTAGE
PAID
MAIL U.S.A.



“Local Service, Nationwide”

**10707 S. 149th Street
Omaha, Nebraska**

Sensus Meters & AMR Equipment
Smith-Blair Clamps & Couplings
Ford Meter Box Company
Febco Backflow Devices
Tyler Fittings & Valve Boxes
Griffin Ductile Iron Pipe
AY McDonald Curb Boxes
Uni-Flange Adapter Flanges
Megalug Mechanical Joint Restraint
Star Pipe Products
McElroy Equipment Rental

American Darling Valve & Hydrants
JM Manufacturing PVC Pipe
PVC Round Meter Boxes
Hymax Couplings & EZ-Max Repair Clamps
Contech Construction Products
Cherne Testing Equipment
Live Tapping Services
Northern Pipe Products
Mueller Gas Distribution Products
ADS HDPE Corrugated Pipe
GPK Products

Phone (800) 247-6811

FAX (402) 896-6379